

Burundi Fiber Optic Sensor Temperature Measurement





Overview

Measurement Type: Point sensing (FBG) or distributed sensing (Raman/Brillouin). Temperature Range: Ensure compatibility with high-temperature environments. Fiber optic temperature sensors are immune to the many environmental effects that compromise other measurement technologies, can be embedded and installed in locations traditional temperature sensors cannot and deliver an unprecedented level of spatial detail and data without sacrificing precision. This is an open access article distributed under the Creative Commons Attribution License, which permits unrestricted use, distribution, and reproduction in any medium, provided the original work is properly cited. A fiber optic temperature sensor is a temperature measurement device that uses optical fibers as the sensing medium.



Burundi Fiber Optic Sensor Temperature Measurement



Infrared fiber-optic sensor for non-contact temperature

It is expected that a non-contact temperature sensor using an infrared optical fiber can be developed for medical and industrial usages based on the

optical-fiber-sensor Companies serving Burundi

Luxtron FluorOptic - Model M-1000 - Fiber Optic Temperature Sensors FluorOptic Temperature Converter for measurements between -200 to 450 °C (-328 to 842 °F) in semiconductor applications.



Fiber Optic Temperature Sensing: Revolutionizing

However, traditional temperature sensors often have limitations, hindering the ability to obtain a comprehensive understanding of thermal profiles. Let's explore fiber



Optical Fiber Sensors for High-Temperature Monitoring:

This paper reviews the sensing principle, structural design, and temperature measurement performance of fiber-optic high-temperature sensors,

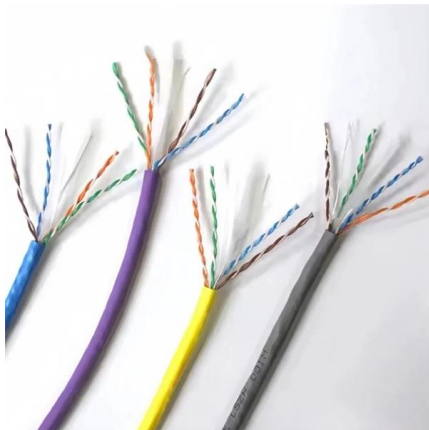

Fiber Optic Temperature Sensors: Types, Working

Explore the structure, working principles, advantages, and disadvantages of Fiber Optic Temperature Sensors for accurate temperature measurement in diverse

Fiber Optic Sensors & Transducers its Types and

Each of these optical fiber temperature sensors can be used to get real-time temperature with a great degree of accuracy and provides precise measurement



Fiber Optic Sensors for Temperature Monitoring during

In this review the current status of the most used FOSs for temperature monitoring during thermal procedure (e.g., fiber Bragg Grating sensors; fluoro optic



Fiber Optic Temperature Sensors



In this chapter, a temperature sensor is demonstrated based on four different techniques; intensity modulated fiber optic displacement sensor (FODS), lifetime measurements, microfiber loop resonator



FOTEMP TS Series Fiber Optic Temperature Probes

The block diagram above illustrates how the fiber optic temperature measurement system works. A broadband light source is coupled into the fiber and impinges on

Fiber optic techniques for temperature measurement

Fiber optic temperature sensors represent devices with the capability of operation in hazardous environments, or with inflammable materials and it is in particular in these areas where such sensors



Waterproof and dustproof, reliable and safe

The outer classic sink design allows the sealing ring of the cabinet and door to be seamlessly compressed without leaving a trace of gaps



Fiber optic temperature sensor, Fiber optic temperature

Find your fiber optic temperature sensor easily amongst the 19 products from the leading brands (SAB, TEXYS, Hellma,) on DirectIndustry, the industry



Fiber Optic Temperature Sensor

Explore the world of fiber optic temperature sensors - their operation, advantages, applications, types, and future outlook in sensor technology.



In-Depth Overview of Fiber Optic Temperature Sensors

Unlike traditional electrical temperature sensors (e.g., thermocouples, RTDs), fiber optic sensors offer significant advantages such as immunity to electromagnetic

Fiber Optic Temperature Sensors

Why use fiber optic sensors? Transducers, such as thermocouples and resistance temperature detectors (RTD), do not always produce satisfactory



FOTEMP TS Series Fiber Optic Temperature Probes

Micronor Sensors offers a complete range of fiber optic temperature sensors, probes and interfaces for high precision temperature measurement in challenging



Fiber Optic Temperature Sensing and Measurement , Luna

Fiber optic temperature sensors are immune to the many environmental effects that compromise other measurement technologies, can be embedded and installed in



Fiber-optic temperature sensing System with extended measurement

This work introduces a fiber-optic temperature sensing system that synergistically combines a Sagnac interferometer (SI) and a Fiber Bragg Grating (FBG) within a fiber ring laser



In-Depth Overview of Fiber Optic Temperature Sensors

A fiber optic temperature sensor is a temperature measurement device that uses optical fibers as the sensing medium. Unlike traditional electrical temperature



Temperature Measurement Using Optical Fiber

The paper deals with the overview of fiber optic methods suitable for temperature measurement and monitoring. The aim is to evaluate the current



Fiber Optic Distributed Sensors for High-resolution

Traditional sensors such as thermocouples cannot fill this role, but the recent development of distributed sensing based on Rayleigh scattering and swept-wave

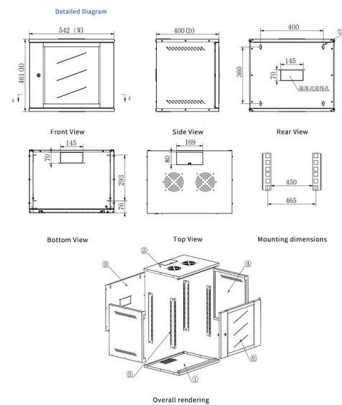

Temperature Measurement Using Optical Fiber

Optical fiber sensors can be used in cases where standard electrical measurement methods cannot be used. These may be areas with high electrical

Temperature Measurement Using Optical Fiber

It is a single point contact temperature measurement system. A Fluorescent sensor is formed at the tip of the Optical Fiber. The other end of the fiber is attached to a light source . The light source is used



Temperature Measurement Using Optical Fiber Methods: Overview

The paper deals with the overview of fiber optic methods suitable for temperature measurement and monitoring. The aim is to evaluate the current research of temperature measurements in the interval



Fiber Optic Temperature Sensors: Operation

Find out more about fiber optic temperature sensors, their principle of operation & how they are applied in industrial temperature measurement.



Fiber Optic Temperature Sensors for High-Voltage

Our temperature sensors are designed with Gallium Arsenide (GaAs) crystals as their fiber tip. They measure temperature fluctuations through shifts in their

Fiber-Optic Sensor for Simultaneous Measurement of Temperature

Fiber Optic Sensor for Simultaneous Measurement of Temperature and Pressure Technology Summary This project is working towards the advancement of multi-point temperature and pressure sensors



Contact Us

For datasheets, pricing, or custom high-speed optical interconnect solutions, please visit:
<https://syropy.com.pl>