

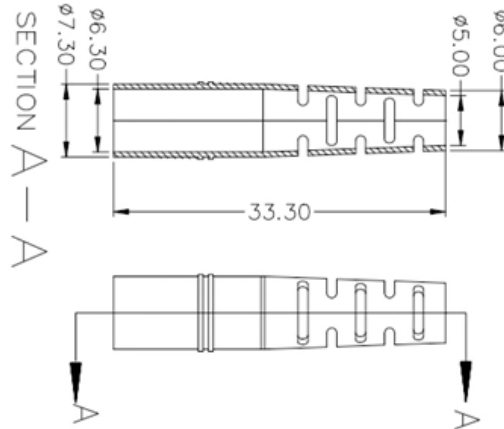

Fire cable tray distributor





Fire cable tray distributor



Fire resistant cable tray , Hermi-solutions

Cable trays are intended for the construction of fire-resistant cable paths. Do you need help with your purchase? The HERMI team will be happy to advise you and

Cable Tray Systems

Channel cable tray secures cables using Eagle Basket pre-punched holes. New pre-punched holes allow the secure attachment of cables to the inside of the channel



Fire Stopping

A compartment needs high quality fire stopping solutions to guarantee its performance. As specialized installers create transitions for cables, ducts or

How Does Fire Protection for Cable Trays Contribute to

Learn how fire protection for cable trays enhances industrial safety by preventing fire hazards in critical areas and protecting infrastructure.



Fire-Resistant Cable Trays in High-Risk Environments

Explore the importance of fire-resistant cable trays in high-risk environments. Learn about the best materials and practices to

Technical Guidelines for Cable Tray Installation and

Install fire barriers within the tray to isolate different fire zones. When cable trays pass through walls or floors, seal openings using fire-rated penetration sealing



Your Wire & Cable Distributor , Best Wire & Cable

Partner with the best wire & cable distributor - Extend your project potential with high-quality and durable cables and wires



Trunking & Cable Trays

A removable glass cloth coated pillow filled with fireproof sponge and intumescent material which expands to 3 times its original size in a fire, stopping gaps in or



FIRE RESISTANT PROOF CABLE TRAY, DIN STANDARD E90

Cablofil fire resistant and fire proof cable trays are increasingly specified in the construction, power, oil, gas, petrochem, rail and utilities industries. Cablofil cable tray has been successfully tested and



Fire-Resistant Cable Support Systems

Check out detailed instructions on fire-resistant installations on our brochure [Download brochure in English: Fire resistant cable support systems v.5 In all fire](#)



Cable Trays and Fire Protection Systems: Keeping

Learn how Cable Trays and Fire Protection Systems work together. They protect cables and help fire alarms, sprinklers, and emergency systems



Combustion characteristics and heat transfer mechanisms analysis of

Focusing on low-smoke, halogen-free, flame-retardant cables, we analyze the effects of cable loading and arrangement on combustion temperature distribution, heat radiation distribution,

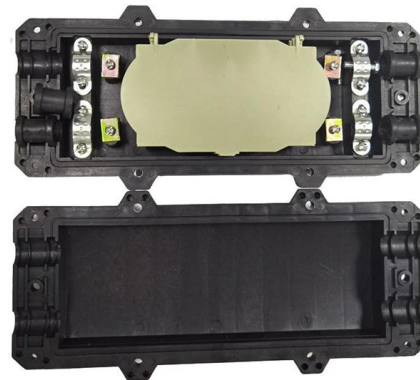

Fire protection for cables & cable trays , Flamro

With our fire protection for cable systems, we ensure that your lines meet the highest safety standards and are reliably protected in the event of an emergency.



Lake Cable Distributor , Instrumentation Cable, Tray

Lake Cable Lake Cable specializes in instrumentation cable, tray cable, thermocouple wire, fire alarm wire, HVAC, broadcast cable, utility cable,

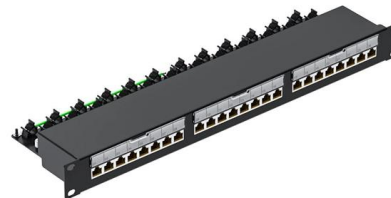

Fireproof Cable Tray Enclosures: Keep Cabling Systems

Cable Enclosures: Secure Your Systems with NEC and NFPA Compliant Solutions Sinisi Solutions works with major utilities and clients to design cable enclosures





Installation Of Cable In Cable Trays: NEC, Safety

Installation of Cable in Cable Trays ensures proper routing, cable management, NEC compliance, grounding, fire safety, and load capacity.

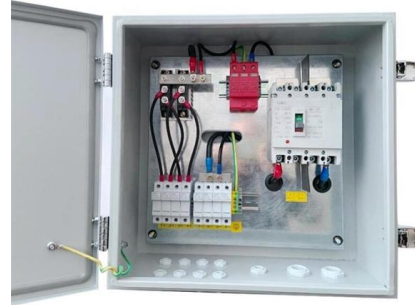

BOSS FyreBox Multi-Service Cable Transit

This product has been designed to allow multiple services to all pass through one single, fire rated enclosure, protecting clusters of electrical, data, comms cables,

Cable tray

Cable tray ABB designs and manufactures cable tray systems, including perforated tray, cable ladder, channel tray and strut (metal framing), directly from production



Cable Tray Covering & Fire Protection

FireResistant Solutions provides cable tray covering and fire-protection systems designed to safeguard electrical and data infrastructure in commercial and multifamily buildings.



Fire Rated Cable Tray, Heavy-Duty Cable Tray Manufacturer

Sealed your operations with our Fire Rated Cable Trays, engineered to keep your electricity supply functional even in fire emergencies. Built to endure heavy loads without collapsing.



Cable Tray Fire Protection: How DLP Systems Suppress

Cable Tray Fires: Protection with Direct Low Pressure (DLP) Fire Suppression Systems Cable trays are an essential part of electrical distribution in

Cable trays

Flexible easy-access jackets with waterproof and water shedding outer cloth for a superior combination of passive fire protection and thermal insulation. Easily



Length:14.5mm
Small-end inner diameter:2.0mm
Large-end inner diameter:3.5mm
Outer diameter:5.2mm

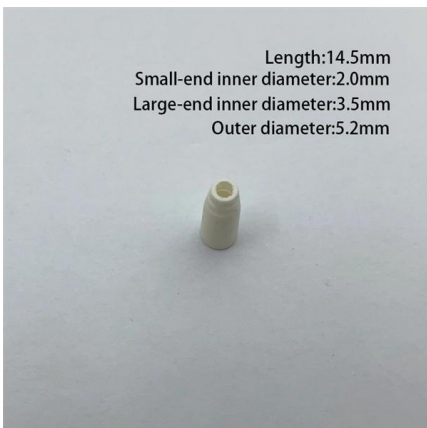

Fire-Rated Cable Tray Supplier: Safety Compliant

Need a Fire-Rated Cable Tray Supplier? Find solutions for safe, compliant cable systems that protect during a fire.



Cable Trays System

Cabel trays, fittings, barrier strips, covers,
accessories 5 Items Show 25 50 75 100 per page
Sort By Cable Trays in various edge heights Edge
Height 35 Edge Height 50 Edge Height 60 Edge
Height 85



Contact Us

For datasheets, pricing, or custom high-speed optical interconnect solutions,
please visit:
<https://syropy.com.pl>