

Maximum and minimum impedance of relay protection





Maximum and minimum impedance of relay protection



High Impedance Restricted Earth Fault Protection

This paper summarizes the operating principle of a high impedance protection unit, its relay sensitivity, related CT requirements, importance of a

Power System Protective Relays: Principles & Practices

(of a relay) The extent of the protection afforded by a relay in terms of the impedance or circuit length as measured from the relay location.
Note: The measurement is usually to a point of fault, but excessive



Distance Protection Relay Settings Guide

This document discusses distance protection relay setting calculations. It provides the following key points: 1. Distance protection relays measure impedance to

Protective relay

Distance relays, also known as impedance relay, differ in principle from other forms of protection in that their performance is not governed by the magnitude of the

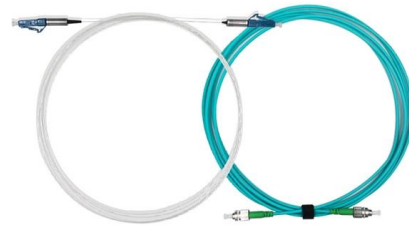

Max Efficiency With The Right Siemens Medium Voltage Current

The encumbrance is the total impedance of the wire, cadence, and relays colligate to the subaltern side. Every connection has opposition, and heat is generated by current square times

1. Distance Protection

Loadability: The Limiting conditions for setting the distance relay reach to avoid encroachment into loads. As per "Reliability Standard PRC-023", The maximum impedance for the distance relay



Line Protection Using Impedance (Distance) Relays

Another option is to use a modified impedance relay (mho relay) which is obtained by offsetting the impedance circle and placing it in the origin. It is directional and



The fundamentals of protection relay co-ordination and

The relay settings are first determined to give the shortest operating times at maximum fault levels and then checked to see if operation will also be

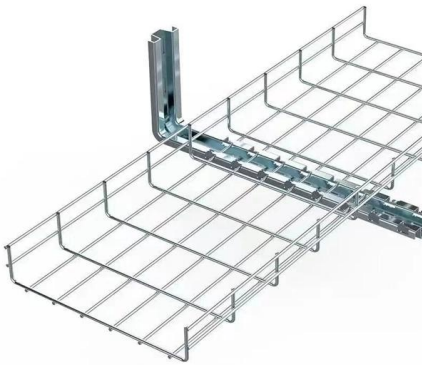

Distance Protection

The type of under-impedance starters used depends on the maximum anticipated load current and the minimum load impedance relative to the protection relay setting needed to cover short circuits in

REF Protection: Technical Guidance for High

Learn about Restricted Earth Fault (REF) protection with this technical guide. Includes theory, schemes, and calculations for 7SR & 7PG23 relays.



Eight most important distance relay characteristics

Distance relay impedance Some numerical relays measure the absolute fault impedance and then determine whether operation is required



Four Special Differential Protections And Their

A differential protection monitors an area limited by CTs which measure incoming and outgoing currents. Now, let's examine following



Protection Basics

Protection System Elements Protective relays
Circuit breakers CTs and VTs (instrument transformers)
Communications channels

Fundamentals of Distance Protection

Distance protection The principle of distance protection is based on the determination of the fault impedance from the measured short-circuit voltage and

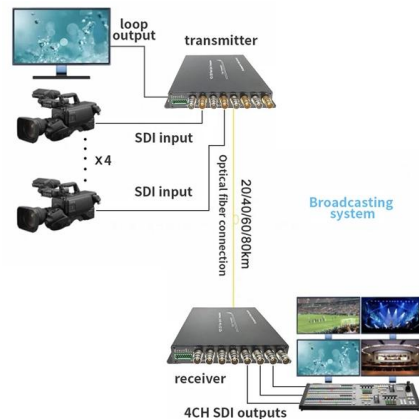

High-Impedance Differential Protection Technical Note

Technical note on high-impedance differential protection principles, calculations, and CT requirements. Includes examples for generator and transformer protection.



Protection Basics

What is the function of power system protection? For what purpose is IEEE device 52 used? Why are seal-in and 52a contacts used in the dc control scheme? In a typical feeder OC protection scheme,



doi: 10.1007/978-3-319-20919-7_3

Perform power system simulations of selected faults and observe how a given protection principle (overcurrent, impedance, and differential) works. Set the relays for a given power system. Verify by

Distance Protection Relay Settings Guide

Distance protection relays measure impedance to detect faults by comparing the measured impedance to a set value. They are used to protect transmission lines



Relays Part 6: Distance Relays Important Theory

Distance relays are designed to detect faulty points in electric circuits. Its operation depends on a measured impedance value. The relay will trip the



Types of Electrical Protection Relays or Protective Relays

The actuating impedance in the relay is the function of



Relaying and System Protection for Electric Utilities Volume III: Line

Preface This course is one of a series of five courses on the design of relaying and system protection programs for electric utilities. These courses describe the fundamental concepts of electric system

Settings Considerations for Distance Elements in Line Protection

Section III reviews general setting recommendations for underreaching (Zone 1) distance elements, including instrument transformer errors, uncertainty of line impedance data, steady-state and



Resistive Reach Calculation of Distance Relay

Resistive Reach of Distance Relay Characteristics is defined by the fault resistance for which the distance relay characteristics is defined. In MHO type distance relay



Impedance Relay

The relay operates when the ratio V/I (i.e., impedance) falls below the particular limiting value of the relay or equivalent distance for which the relay

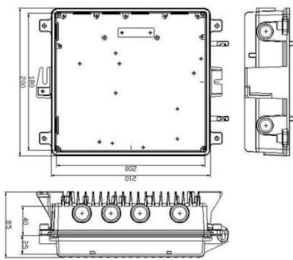

Distance Relay: Types, Diagrams, and Working Principles

A distance relay is a protective device that measures line impedance to detect and isolate faults in high-voltage transmission systems with speed and precision.

Insert Title here (Style: Paper title)

Indeed the protective relay is connected in series with such a large impedance that the maximum through fault will be prevent from initiating an unwanted relay operation , , , and .

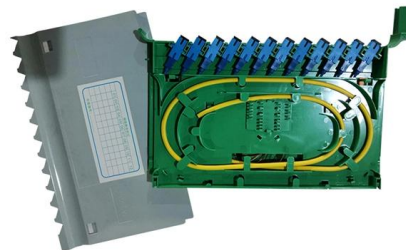

doi: 10.1007/978-3-319-20919-7_3

Impedance relays are used whenever overcurrent relays do not provide adequate protection. This section provides exercises about how to use impedance (distance) relays to protect a power network.



Contact Us

For datasheets, pricing, or custom high-speed optical interconnect solutions, please visit:

<https://syropy.com.pl>