

Optical cable for photometer





Overview

Fiber optic cables used in photometry have FC connectors, which have a 'notch-and-key' system. Thorlabs offers a full line of equipment for in vivo stimulation, including implantable fiber optic cannulae, fiber optic patch cables, rotary joints, and LED and laser light sources. For the 3-color setup, the Lux LEDs output light through a series of bandpass filters and dichroic mirrors ('fluorescent ports') called a Lux Optical Manifold (LxM6) that send excitation light to the subject and receive fluorescence back. This product is an accessory for the following products: 260 to 880nm, single or dual wavelengths. Inline, flexible, fiber optic process analyzer systems enable users to place measurement probes remotely and at multiple points with one instrument, dramatically. Combine the high accuracy and wide photometric range of a Thermo Scientific™ GENESYS™ or Thermo Scientific Evolution™ UV-Vis Spectrophotometer with the convenience of cuvette-free measurements.



Optical cable for photometer



Applications Notes

The Photometer Module allows for easy connection to PendoTECH's UV flow cells through the fiber optic cable connections on the front of the unit. The Photometer Module does not have a local

Process photometer

This is achieved from a state of the art digital photometer design using a modulated high performance UV LED light source with precision fiber optics. Traditional UV



Optical Connections

The cables have color-coated necks to identify which Lux LED or Photosensor they attach to. The cable specs and important connection considerations are

DCP007-NIR Photometer

The Kemtrak DCP007-NIR photometer uses precision fiber optics to shine a precisely focused monochromatic light through the process medium and back to



Photo Electric Control Cables

Fiber optic cables may be made from plastic or glass fibers. Glass cables can transmit infrared wavelengths, and will withstand harsh environments better.



Thorlabs · Fiber Photometry Overview

We have extensive patch cable capabilities including a large, diverse stock of optical fiber and many different types of fiber connectors. If you do not see a stock cable

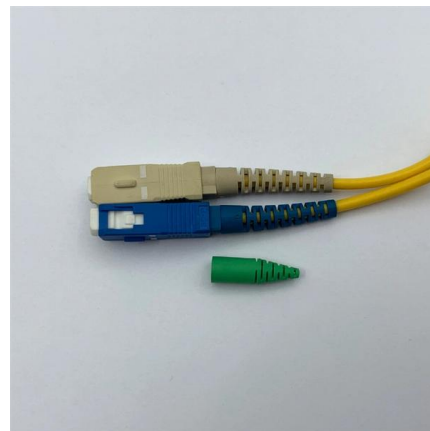

Photometric measurement and control systems

Pier-Electronic offers a suitable optical measurement method for every measurement task, whether by transmission photometers, which measure the transmission of a





Your guide to fiber optic probes

The 2 m long glass fiber cables give you the freedom to measure at a significant distance from the spectrophotometer, and specially shortened collars on the SMA connectors make the probe



The Photometer System

A photometer (measuring) diaphragm in the plane of a real image for selection of the area to be measured on the stage object. Optics for viewing the photometer diaphragm, either directly or as re

Photometer

The photometer head is connected to a calibrated readout unit. In a telephotometer used for luminance measurements the measuring head incorporates a telescopic optical system focused onto the

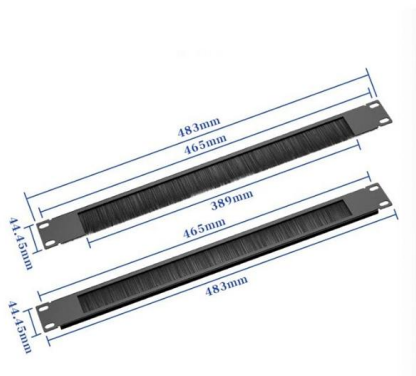
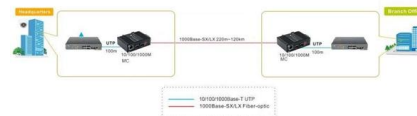

PENDOTECH UV-VIS-NIR USER MANUAL Pdf Download , ManualsLib

Page 9 PendoTECH UV-VIS-NIR Photometer for UV Absorbance and Turbidity Measurements User's Manual Revision 3 Photometer, front view Complete system setup showing measure



Optical power meter

Optical power meter Home Products Fiber Optic Testing The ideal complementary tool for any fiber-testing An optical power meter (OPM) is a device used to

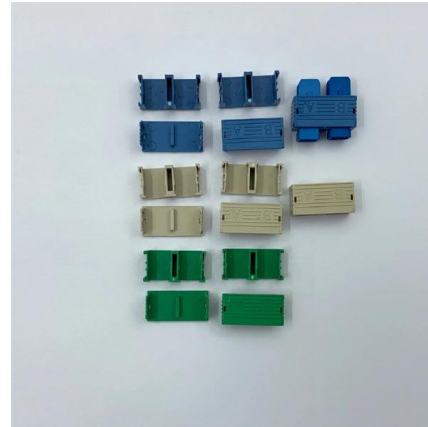

PX2 Fiber Optic Photometer -- Firebird Optics

Firebird Optics carries a line of UV/VIS/NIR photometers with fiber optic connections meant to be paired with our process flow cells and fiber optic probes. The PX2

Photometer and radiometer

The photometer frc'3 enables a simple, precise, and absolute light measurement. Designed for the use in harsh surroundings and equipped with high-precision



PendoTECH® Single Use UV Flow Cells and PM2 Photometer

PendoTECH® Single Use UV Flow Cell and UV PM2 Photometer offers a non-invasive way to make this measurement. The flow cell is connected to the PM2 system with fiber optic cables, which connect to



Optical Fiber Spectroscopy

Using optical fibers can help you capture and waveguide emitted light efficiently. As you can see in the above graph, the signal intensity (and therefore signal-to-noise ratio) is greatly improved by using



PendoTECH Optical Fiber Photometer Cable , BioPharm World

This product is an accessory for the following products: 260 to 880nm, single or dual wavelengths. Need Help? Call an expert at 1-800-795-6436. We're open 8:00 am to 5:00 pm ET.

Fiber Optic Cable Selection , GUIDED WAVE

From a patented fiber design to an emphasis on high-quality materials, Guided Wave spectroscopic grade optic cable is designed for the highest performance in



Digital Photometer

Another common photometer is the optical sensor in many point-and-shoot cameras. It is an internal photometer combined with sophisticated electronics that control the lens opening and shutter speed



Fiber Optic Cables

Our lab-grade and premium-grade UV-Visible optical fiber assemblies are durable, high-quality patch cords that deliver uniform results with minimal signal variance.



Fiber Optic Cable , Farnell® Germany

Buy Fiber Optic Cable. Farnell® Germany offers fast quotes, same day dispatch, fast delivery, wide inventory, datasheets & technical support.



Photometers for different applications | GL Optic , ENG

Accurate photometers with high sensitivity, laboratory level V-lambda correction for different light measurement applications.

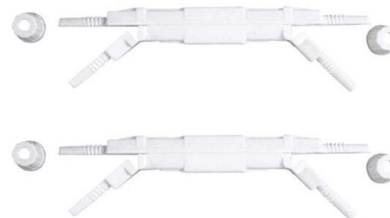

Specification Sheet

The flow cell is connected to tubing, and the measurement is made by use of a compact photometer with fiber optic cables. This flow cell contains a special silica glass lens on the wall and compartments to



PENDOTECH Optimize Viral Vector Production Application Note

UV absorbance measurements with PM2 photometer with minimal disruption compared to offline measurements. The flow cell is connected to the PM2 system via fiber optic cables, which can be



DCP007-VIS Photometer

Measures color and concentration. The Kemtrak DCP007 is an easy to operate, in-line and real time industrial fiber optic photometer.

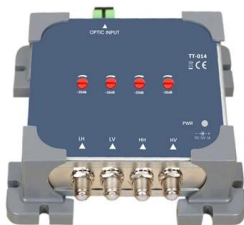

DCP007-UV Photometer

The Kemtrak DCP007 UV process analyzer uses ultra-low power cold light at the exact wavelength required for the analysis, exposing the sample to thousands of

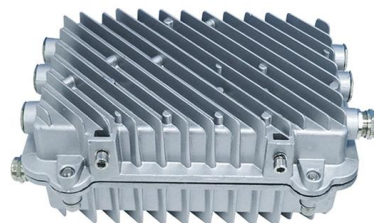

Fiber optic photometer

The Kemtrak DCP007 is an easy to operate industrial fiber optic photometer designed to accurately measure the concentration and color of process samples.



Kemtrak DCP007 NIR Process Photometer for in-line measurement

The Kemtrak DCP007-NIR process analyzer is a high performance fiber optic coupled near-infrared (NIR) photometer for high resolution, real time, inline concentration measurement.



Contact Us

For datasheets, pricing, or custom high-speed optical interconnect solutions, please visit:
<https://syropy.com.pl>